



CE

Special Features

- Stainless steel case & high precision measuring system
- High resolution dial
- Anti parallax mirror band (eye friendly)
- Socket directly welded to case
- Standard followed in general EN 837-1
- Calibration certificate with traceability to National / International standards.

Application

- Calibration / testing in laboratory
- Fits for various process Industries and all gaseous / liquid media that will not obstruct the pressure system



High Precision Jeweled Bearing Movement



Beryllium Copper Tube



SS 316L Tube

Specifications

Standard Version : 150 mm, 200 mm & 250 mm

Accuracy	: ± 0.5 of F.S. (For TG Model) & $\pm 0.25\%$ of F.S. for (MG Model) (At $+20^\circ\text{C}$)
Ambient temperature	: Maximum 65°C
Process temperature	: Maximum 65°C
Operating pressure range	: 75% of the Scale Value
Case & Bezel	: AISI 304 SS (Bayonet Type)
Bourdon	: AISI 316L SS for Accuracy $\pm 0.5\%$ & Beryllium Copper for Accuracy $\pm 0.25\%$
Socket	: AISI 316L SS (Optional Brass Socket for $\pm 0.25\%$ Accuracy if Required Only)
Movement	: AISI 304 SS for Acc. $\pm 0.5\%$ & High Precision Jewel Bearing Type (Brass Movement) for Acc. $\pm 0.25\%$
Integral Dampening Screw	: AISI 316 SS
Protection	: IP 68
Dial	: Aluminum, Green with Black Marking & Anti Parallax Mirror Band
Pointer	: Balanced, Knife Edge Micrometer Adjustable
Pointer Stopper	: Spring Type
Gasket	: Neoprene
Welding	: Alloy Brazing
Window	: Toughened / Shatter proof Safety Glass
Blow Off Disc	: Neoprene
Carrying Case	: Wooden or Plastic carrying case
Calibration certificate	: Calibration certificate traceable to National / International standard.

Temperature effect :

The variation of indication caused by effects of temperature is to be calculated by below formula; which is to be added in the specified accuracy while measurement :- Formula : $\pm 0.04 \times (t_2 - t_1) \%$ of F. S. where t_1 = reference temperature ($+20^\circ\text{C}$) and t_2 = ambient temperature in $^\circ\text{C}$.

Dimensions - standard version

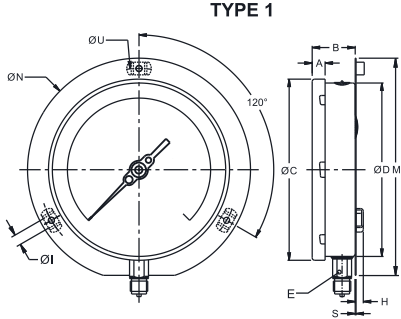

NS	A	B	ØC	ØD	E	M	ØN	ØU	H	ØI	S	Weight in gram (With Box)
150	15	49	161	149	22	174	186	168	14.5	6	6	1160.0
200	18	49	216	200	22	229	245	230	14.5	7	1.5	2050.0
250	18	55	262	247	22	286.5	290	276	14.5	7	1.5	2450.0

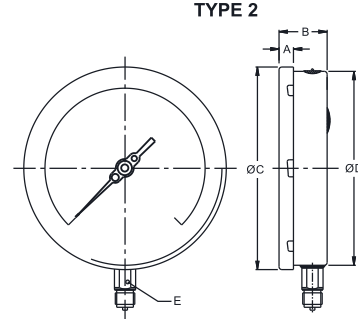

NS	A	B	ØC	ØD	E	Weight in gram (With Box)
150	15	49	161	149	22	1100.0
200	18	49	216	200	22	1975.0
250	18	55	262	247	22	2375.0

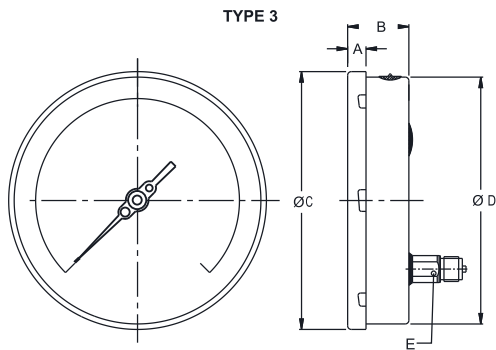

NS	A	B	ØC	ØD	E	Weight in gram (With Box)
150	15	49	161	149	22	1075.0
200	18	49	216	200	22	1950.0
250	18	55	262	247	22	2350.0

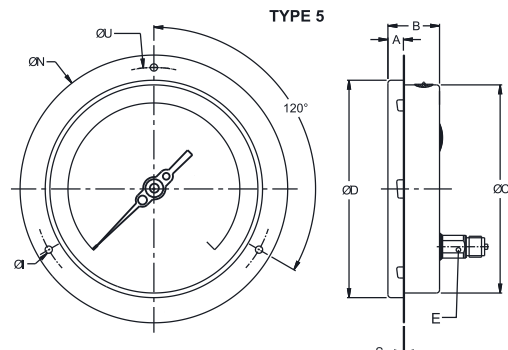

NS	A	B	ØC	ØD	E	ØN	ØU	ØI	S	Weight in gram (With Box)
150	15	49	149	161	22	186	168	6	5	1160.0
200	18	49	201.5	216.5	22	245	230	7	1.5	2030.0
250	18	55	250	263	22	290	276	7	1.5	2480.0

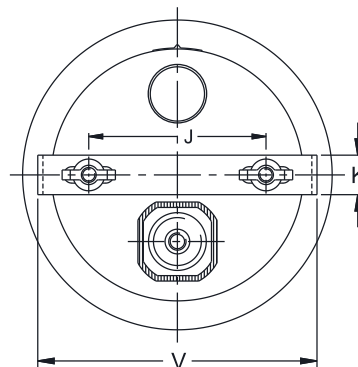
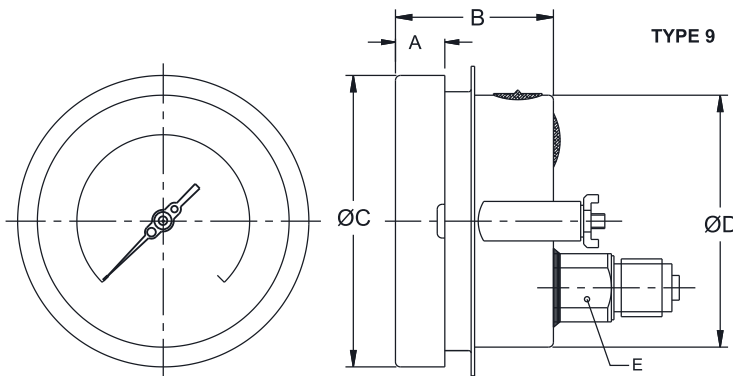

Notes : • Drawings are not to scale.
• All Dimensions are in mm.
• NS = Nominal Size.

NS	A	B	ØC	ØD	E	J	K	V	Weight in gram (With Box)
150	15	49	161	149	22	106.5	16	166	1120.0
200	18	49	216	200	22	165	16	208	1950.0
250	18	55	262	247	22	180	30	270	2300.0



a unique innovation, with trust and quality...

TG

SS Case Test Gauge (Accuracy $\pm 0.5\%$)
Bourdon type

MG

SS Case Test Gauge (Accuracy $\pm 0.25\%$)
Bourdon type

Range Table

Note : We offer National / International Scales like kPa, MPa, bar, psi, kg/cm² & Dual Scale like kPa with psi, kPa with bar, bar with psi or Equivalent scales as per the requirement can be provided on request. Following are the example tables for kg/cm² or bar

Pressure range

Single scale (kg/cm ² or bar)					
0/0.6	0/4	0/25	0/160	0/1000	
0/1	0/6	0/40	0/250		
0/1.6	0/10	0/60	0/400		
0/2.5	0/16	0/100	0/600		
Dual scale (psi with kg/cm ²)					
psi	kg/cm ²	psi	kg/cm ²	psi	kg/cm ²
0/15	0/1	0/400	0/28	0/4000	0/280
0/30	0/2	0/500	0/35	0/5000	0/350
0/60	0/4	0/600	0/40	0/6000	0/420
0/100	0/7	0/1000	0/70	0/10000	0/700
0/150	0/10	0/1500	0/100	0/15000	0/1000
0/230	0/16	0/2300	0/160		
0/300	0/20	0/3000	0/200		

Vacuum range

Single scale		Accessories (Refer Datasheet for complete specifications)
(kg/cm ² or bar)	(mmHg)	GS Overload protector (gauge saver)
- 1/0	- 760/0	

Note : Other Scale are available on customer request.

Please refer to factory. Compound ranges are not preferred.

How To Order

How To Order					Example
Basic Model					TG or MG
Code					
Nominal Size	60	80	100		XX or XXX
	150 mm	200 mm	250 mm		
Type of Mounting					
1	Wall / surface / projection	3	Direct lower back entry		X
	Mounting with bottom entry	5	Lower back entry with front flange		
2	Direct bottom entry	9	Lower back entry with mounting bracket		
Gauge Connection					
4BM	½" BSP (M) Standard	2NM	¼" NPT (M)	4NM	½" NPT (M) Standard
Range					XXX
Refer range table					0/10 kg/cm ²
Optional Extras					
CDD	Custom designed dial	HLT	Helium leak test		XX
TND	Tag Marking no on Dial	PLG	Plexi glass		
STP	SS tag plate				

Ordering Example: TG . XX . X . XXX . 0/10 kg/cm² . XXX

For other optional items, please contact factory for delivery and minimum quantity of order.

Note : Specifications and dimensions given in this product catalogue represents the state of engineering at the time of printing.

Modifications may take place and materials specified may be replaced by others without prior notice.